

ROADMAX® SERIES LUMINAIRES

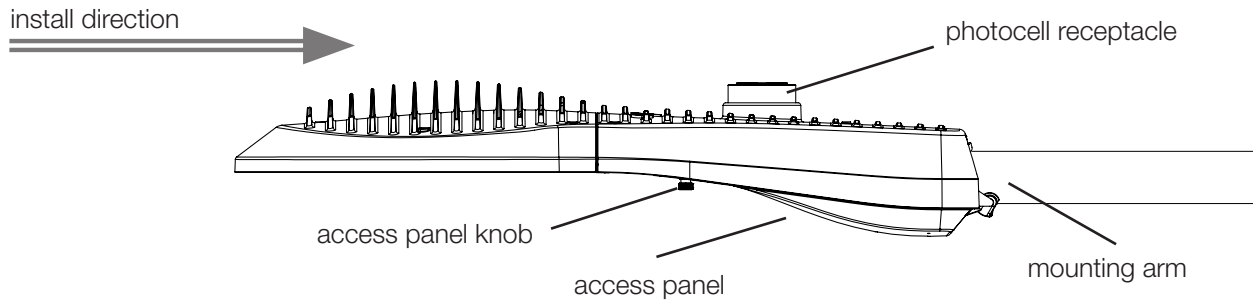

ROADMAX RX2 & RX3 LUMINAIRE INSTALLATION INSTRUCTIONS



PLEASE READ AND FOLLOW ALL SAFETY INSTRUCTIONS!

Disconnect power before wiring the fixture. High voltage may be present even when the photocell is removed.
If not qualified, consult an electrician.



Verify that supply voltage is correct.

Do not exceed maximum voltage marked on luminaire label.

LED luminaires should be powered directly from a switched service unless specification indicates otherwise. Do not connect directly to control devices, such as occupancy sensors, timing devices or dimmer packs.

Follow all National Electrical Codes (NEC) and any applicable local code requirements for electrical and grounded connections. Wiring connections should be capped with UL listed or recognized connectors.

Wear gloves and safety glasses when removing luminaire from carton, during installation, or while performing maintenance.

Avoid direct eye exposure to an LED light source while in operation.

PRODUCT DESCRIPTION

The RoadMax RX2 and RX3 have been listed to U.S. and Canadian safety standards CSA per Met Labs. It is suitable for use in wet locations. Temperature operation range is -40°C min to 50°C max.



This device complies with Part 15 of the FCC Rules. Operation is subject to the following two conditions: (1) this device may not cause harmful interference, and (2) this device must accept any interference received, including interference that may cause undesired operation.

This luminaire is designed for outdoor lighting purposes. It should not be used in an area with limited ventilation or an enclosed area with a high ambient temperature. Store in a dry location prior to installation. Do not expose luminaire to the weather without a shorting cap or photocell installed unless the luminaire has been ordered with the Evluma integrated photocell.

TOOLS REQUIRED

- 9/16 in drive socket, or box wrench for tenon bolts
- #2 Phillips screwdriver for photocell receptacle
- 5/16 in drive socket, or 1/4 in slotted screwdriver for secondary lens (LENSG1) or shields (LTS)
- 1/4 in slotted, or #2 Phillips screwdriver for terminal block fasteners

If you are installing a secondary lens or light trespass shields, attach to the luminaire prior to hanging the luminaire. Please see the separate instructions for installing these accessories, available on evluma.com. Installing a photocell, steps 8 and 9, may be easier to perform on a workbench than on a pole. Likewise, setting the FAO (Field Adjustable Output switch), step 7, can be done in advance, prior to installation. Please review the entire guide before proceeding.

1. Disconnect power to reduce the risk of electrical shock.
2. Open the access panel using the access panel knob by rotating approximately 2 turns.
3. Using the 9/16 inch drive socket, loosen (do not remove) the four tenon clamp bolts enough to allow the mounting arm (not included) to slide into the service cavity.
4. Insert the mounting arm. RoadMax luminaires accept 2 inch or 1-1/4 inch mounting arms and accommodate a maximum outside diameter of 2-3/8 inches. Luminaires are set at the factory to accept a 1-1/4 inch mounting arm.

The mounting arm should be placed upon or 'stopped' against the leveling steps. Use caution and avoid striking internal components with the mounting arm. Leveling steps are designed to be used in conjunction with the bubble level to install the luminaire in a straight or level position.

Note: A wildlife guard is provided for use with a 1-1/2 inch diameter mounting arm or smaller. If using a mounting arm larger than 1-1/2 inches remove the wildlife guard. See instructions for Removing or Installing the Wildlife Guard,

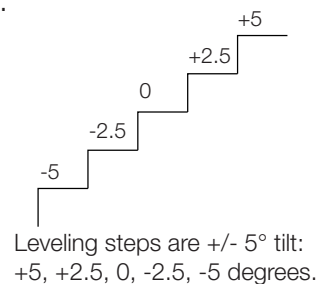

REAR VIEW

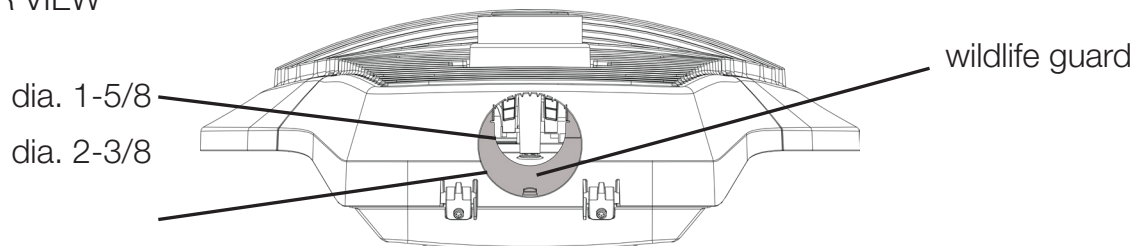

5. Tighten the bolts to 120 in-lbs, alternating from bolt to bolt. Refrain from tilting the clamp or unevenly tightening the bolts to avoid cross-threading. Using the bubble level, confirm that the luminaire is level.
6. Pull the wires through the mounting arm. Allow for enough length to easily attach to the three-position terminal block. Loosen the terminal block screws prior to connecting wires. Use 1/4 inch slotted, or #2 Phillips screwdriver for securing conductive wires in the terminal block, torque to 15 in-lbs.

Wire for the appropriate voltage.

Note: A reference wiring diagram can be found inside the access panel. Exact steps may vary depending on if pigtailed (white, black and green wires) are included with the luminaire vs. a no lead option.

7. If you have ordered a luminaire with an FAO (Field Adjustable Output switch) installed and you intend to use this to set a lower wattage, do so at this time if you have not done so already. Please refer to the RX2 datasheet TP-0067, or the RX3 datasheet TP-0076 for details. Datasheets are available on evluma.com.
8. Rotate the photocell receptacle if position requires adjustment. By default, North is oriented to the front of the luminaire. Use a #2 Philips screwdriver for photocell receptacle or photocell only if rotation is required. Torque to 25 in-lbs. The Evluma integrated photocontrol can be rotated 360°.
9. Insert a twist lock photocell or network node into the photocell receptacle and install in accordance with the manufacturer's instruction.

Note: Before installing a node on an RX2 or RX3 with an F7 (7 pin) receptacle configuration, please contact Evluma Customer Support at customercare@evluma.com for additional instructions and reference the wiring diagram located on the inside of the access panel.

10. Close the access panel. Tighten the access panel knob. Do not overtighten.
11. With power on, test the photocell.

Note: Photocells and photocell test response times may vary. Some photocells may turn the light off and on over the first few minutes after power is applied. This does not indicate a defect. A defective photocell will operate with the light on at all times regardless of the time of day. Allow several minutes for the photocell to turn the fixture off. A small number of photocells fail off. Test according to the type of photocell in use.

If the luminaire comes with the Evluma integrated photocell (SP or FP model) allow up to 5 seconds for the luminaire to respond.

PHOTOCONTROL FAILSAFE™

If the RoadMax has been ordered with Photocontrol Failsafe the luminaire will flash, or pulse, once to indicate that power is connected, and luminaire is in operation. The RoadMax begins collecting data immediately. Short daytime tests of the photocell will not affect the gathering of this data.

WARRANTY

Warranty information may be found at evluma.com. Components inside the fixture are not serviceable.

NEED ASSISTANCE?

Please feel free call us at 425-336-5800 M-F, 8am- 4pm PST, or email customercare@evluma.com.

REMOVING OR INSTALLING THE WILDLIFE GUARD

RoadMax tenon clamps accept 2" or 1-1/4" diameter arms. RoadMax ship with the wildlife guard installed. The wildlife guard is designed to prevent wildlife from entering the housing through the gap between the housing and the mounting arm. If you know you will be using a larger diameter mounting arm, you may wish to remove the wildlife guard prior to installing the luminaire on the pole. The following instructions show removal being performed on a workbench.

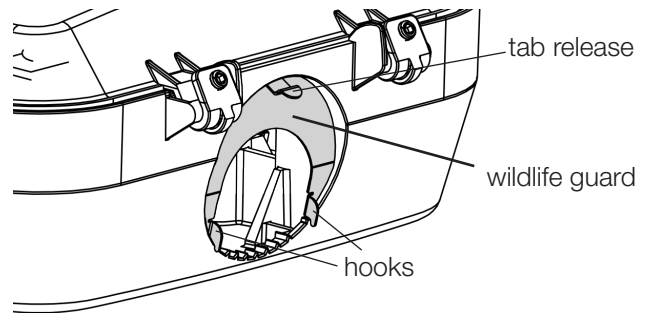
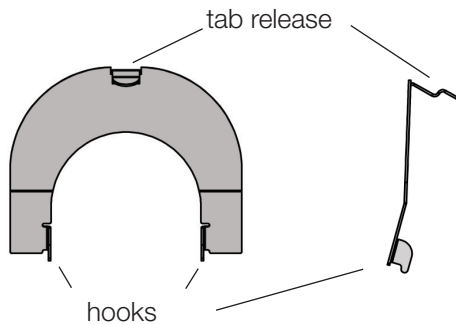

To Remove the Wildlife Guard

1. Open the access panel until it rests on the workbench. Locate the wildlife guard at the back of the luminaire.
2. Press down on the tab release and let the guard fall against the tenon clamp.
3. Lift the guard up so that the hooks clear the housing, then pull up to remove from the luminaire. Save for later use if needed.

To Install the Wildlife Guard

1. Open the access panel until it rests on the workbench.
2. Insert the wildlife guard between the tenon clamp and the housing.
3. Align the wildlife guard with the mounting arm hole in the housing.
4. Angle the guard so that the hooks catch the housing. Each hook should rest next to the outermost set of teeth.
5. Press down on tab release until it clears the housing. Push the guard against the housing and snap it into place. The tab release should spring back up and hold the guard in place.

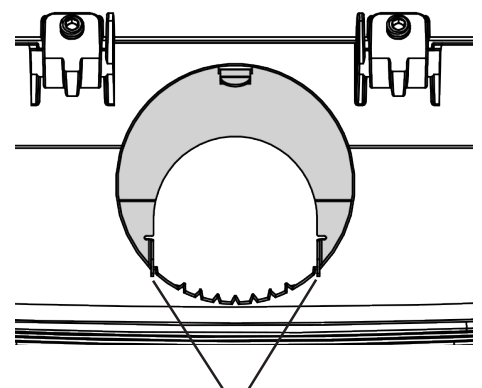
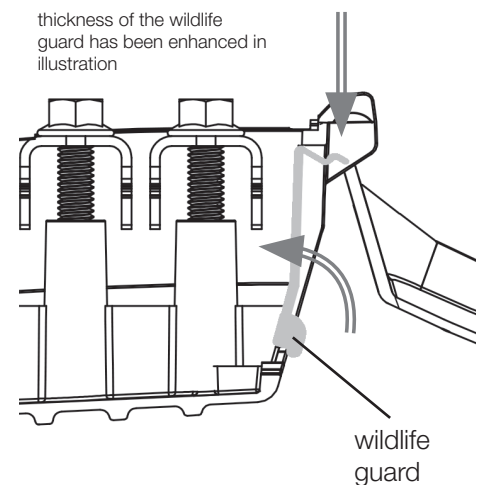

Align the hooks with the outermost set of teeth in the mounting arm hole

Part Number Reference

A wildlife guard comes with every RoadMax. Should a replacement be required, please reference the following part numbers:

- 100813-001 GUARD, STEEL, GALVANIZED, ROADMAX
- 100813-002 GUARD, COASTAL, ROADMAX